

Prestige

ARCHITECTURAL ROOFING

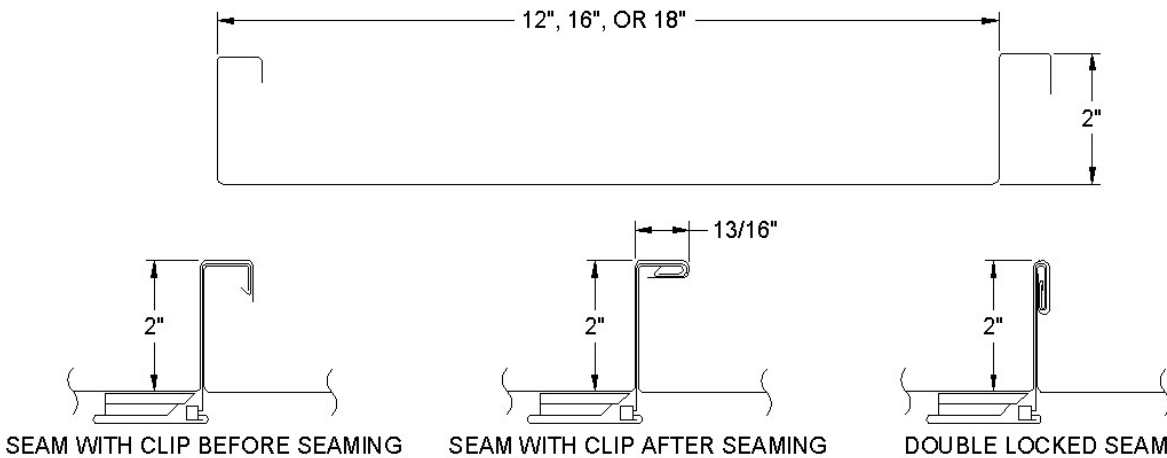

Effective September 2007



ALLOWABLE GRAVITY LOADS (PSF)

substrate	width	3.0'	3.5'	4.0'	4.5'	5.0'
24 ga. steel	12"	75	72	69	67	64
24 ga. steel	18"	50	48	46	44	41
22 ga. steel	12"	95	91	87	84	81
22 ga. steel	18"	63	61	58	56	53

Notes:

1. Allowable loads are based on 1980 edition of AISI specifications.
2. Deflection is limited to L/240 of span.
3. Loads are based on spans of 3 or more.
4. FY = 50 ksi for steel panels.
5. Uplift values based on attachment to 16 ga. purlins with 2 #10-16 x 1" SD ST screws.

DESIGN INFORMATION

Shadow lines are standard.

The AMP Lok panels can be custom tapered to a minimum width of 2" and a maximum width of 18". The maximum length of tapered panels is 40'. Shadow lines are not available on tapered panels.

The maximum purlin spacing for AMP Lok panels is 5'.

The minimum roof pitch is 1:12.

Maximum panel length is 65'.

Minimum panel length is 4'.

TEST REPORT SUMMARIES

AIR INFILTRATION: had 0.01 cfm/ft.² leakage with 15 psf pressure differential per ASTM E 283.

WATER RESISTANCE: No water penetration under 5 gal./hr. spray at 6.24 psf pressure differential per ASTM E 331.

UL90 UPLIFT RATING: 16" wide, 24 ga. steel panels with clips installed over 16 ga. purlins (40 ksi steel) and spaced maximum of 5'-0" o.c. with one screw per clip. Insulation varies with Construction No. (Construction No. 90 (2 screws required), 176, and 180).

UL90 UPLIFT RATING: 16" wide, 24 ga. steel panels with clips spaced a maximum of 48" o.c. over rigid insulation (min. 1" thick and 2.0 pcf) over 22 ga. steel deck (33 ksi) with one #11 x 3 3/4" long self-drilling screw with Phillips drive and flat head per clip and bearing plate under each clip. Bearing plate size is 3" x 3 1/4" x 0.050". (Construction No. 238).

UL90 UPLIFT RATING: 18" wide, 24 ga. steel panels with clips spaced a maximum of 2'-0" o.c. installed over 1/2" plywood deck with two #12-14 x 1" pancake head screws per clip. (Construction No. 548).

UL90 UPLIFT RATING: 16" wide, 24 ga. steel panels with clips a maximum of 5'-0" installed over 5/8" plywood with two #10 x 1" pancake head screws per clip. (Construction No. 549). Fabral recommends a maximum clip spacing of 2' o.c. for installations over plywood.

ASTM E 1592: 24. steel panels at 2'-6" and 5'-0" spans over open purlins. Design uplift loads for 18" wide 24 ga. steel panels (single locked) are 35.15 psf for 5'-0" clip spacing and 29.09 psf for 2'-6" clip spacing. Design uplift load for 16" 24 ga. steel panels (double locked) are 58.79 psf at 5'-0" clip spacing and 67.88 psf at 2'-6" clip spacing.

Prestige

ARCHITECTURAL ROOFING



MATERIAL, THICKNESS, & WIDTH	WT./SQ. PLAIN	WT./SQ. PAINTED	METAL SPECIFICATION	FINISH
GALVANIZED STEEL			Grade 50 (50 ksi yield strength) with G90 coating, both conforming to ASTM A 653.	plain: regular spangle painted: two-coat 70% Kynar [®] 500/Hylar [®] 5000; 0.5 mil two-coat polyester backer.
24 ga. (12")	153.0 lb.	154.5 lb.		
22 ga. (12")	186.6 lb.	188.8 lb.		
24 ga. (16")	140.2 lb.	141.6 lb.		
22 ga. (16")	171.0 lb.	172.8 lb.		
24 ga. (18")	136.0 lb.	137.3 lb.		
22 ga. (18")	165.8 lb.	167.5 lb.		
ALUMINUM-ZINC ALLOY COATED STEEL			Grade 50 (50 ksi yield strength) with AZ50 coating, both conforming to ASTM A 792.	plain: regular spangle painted: two-coat 70% Kynar [®] 500/Hylar [®] 5000; 0.5 mil two-coat polyester backer.
24 ga. (12")	148.5 lb.	150.0 lb.		
22 ga. (12")	181.2 lb.	183.3 lb.		
24 ga. (16")	136.1 lb.	137.5 lb.		
22 ga. (16")	166.0 lb.	167.8 lb.		
24 ga. (18")	132.0 lb.	133.3 lb.		
22 ga. (18")	161.0 lb.	162.6 lb.		



Jackson, GA (800) 884-4484
 Grapevine, TX (800) 477-9066
 Salem, OR (800) 477-8028
 Headquarters - Lancaster, PA (800) 477-2741

Prestige

SPECIFICATIONS

PART I GENERAL

1.01 SUMMARY

- B. Section includes: all material, labor, and equipment to complete installation of Amp Lok as shown on the drawings and herein specified. Include all copings, gutters, and flashings contiguous with the panels.
- C. Related Sections
 - 1. Metal decking
 - 2. Rough carpentry, plywood, and underlayment
 - 3. Insulation
 - 4. Membrane roofing
 - 5. Flashing and sheet metal
 - 6. Joint sealers: sealants and caulk
 - 7. Structural framing.

1.02 REFERENCES

- A. American Society for Testing and Materials (ASTM)
 - 1. ASTM A 653: Steel Sheet, Zinc-Coated by the Hot Dip Process
 - 2. ASTM A 792: Steel Sheet, Aluminum-Zinc Alloy Coated by the Hot Dip Process.
 - 3. ASTM E 283: Air leakage
 - 4. ASTM E 331: Water penetration
- B. Underwriters Laboratory
 - 1. UL Building Materials Directory
- C. Sheet Metal and Air Condition Contractors National Association, Inc. (SMACNA)
 - 1. SMACNA Architectural Sheet Metal Manual, 1993 Edition.
- D. American Iron and Steel Institute (AISI)
 - 1. AISI Cold Formed Steel Design Manual
- E. Metal Construction Association (MCA)
 - 1. Preformed Metal Wall Guidelines
- F. Code references
 - 1. ASCE, Minimum Loads for Buildings and Other Structures
 - 2. BOCA National Building Code
 - 3. UBC Uniform Building Code
 - 4. SBC Standard Building Code
 - 5. IBC International Building Code

1.03 SYSTEM DESCRIPTION

- A. Performance Requirements: Provide factory formed, prefinished, mechanically seamed, concealed clip, structural standing seam metal roof system, that has been pretested and certified by manufacturer to comply with specified requirements under installed conditions.
 - 1. Provide UL90 rated roofing system that has been tested in accordance with UL 580 test procedure.
 - 2. Resistance to air leakage: 0.01 cfm/ft. of joint leakage when tested in accordance with ASTM E 283 at static pressure differential of 15 psf.
 - 3. Resistance to water penetration: No leakage through panel joints when tested in accordance with ASTM E 331 at static pressure differential of 6.24 psf.
- B. Structural Requirements: Engineer panels for structural properties in accordance with latest edition of American Iron and Steel Institute *Cold Formed Steel Design Manual*, using "effective width" concept.
- C. Maximum clip spacing shall be 5' o.c.

1.04 SUBMITTALS

- A. Product Data: submit manufacturer's specifications, standard profile sheet, product data brochure and finish warranty.
- B. Shop Drawings: shop drawings showing roof plan with layout of panels, clips, clip attachment, underlayment and sections of each flashing/trim condition shall be submitted for approval prior to fabrication. Drawings shall contain material type, metal thickness and finish. Drawings shall distinguish between factory and field fabrication.
- C. Samples:
 - 1. Submit sample 12" long x full width panel, showing proposed metal gauge, seam profile and specified finish.
 - 2. Submit manufacturers standard colors for Architect's selection.
- D. Test Reports:
 - 1. Submit the test reports prepared by Underwriters Laboratory indicating wind uplift rating of proposed roof system. The manufacturer must be listed by name in the UL Directory.

- 2. Air leakage per ASTM E 283 and water penetration per ASTM E 331. (Actual independent laboratory certified test results must be submitted).
- E. Certification: Submit manufacturer's certification that materials and finishes meet specification requirements.

1.05 QUALITY ASSURANCE

- A. Panel manufacturer shall have a minimum of ten (10) years of experience in manufacturing architectural roofing in a permanent stationary indoor facility.
- B. Panel installer shall have a minimum of two (2) years experience in the installation of concealed clip architectural standing seam metal roofing and show evidence of successful completion of at least three (3) projects of similar size, scope, and complexity.

1.06 DELIVERY, STORAGE, and HANDLING

- A. Panels and flashings shall be protected and properly packaged to protect against transportation damage in transit to the jobsite.
- B. Upon delivery, exercise care in unloading, stacking, moving, storing, and erecting panels and flashings to prevent twisting, bending, scratching, or denting.
- C. Store panels and flashings in a safe, dry environment under a waterproof covering to prevent water damage. Allow for adequate ventilation to prevent condensation. Panels and flashings with strippable film shall not be stored in direct sunlight.
- D. Upon installation immediately remove strippable film from panels and flashings. Protect panels and flashings from foot traffic and from all other trades.

1.07 PROJECT CONDITIONS

- A. Field dimensions shall be taken prior to fabrication to verify jobsite conditions.
- B. Minimum recommended pitch for this panel is 1:12.
- C. Maximum panel length is 65' (contact the factory for longer panels).

1.08 WARRANTIES

- A. Panel manufacturer shall provide a twenty (20) year warranty on the paint finish covering chalking, cracking, checking, chipping, blistering, peeling, flaking, and fading.
- B. Applicator shall furnish written warranty for a two (2) year period from date of substantial completion of building covering repairs required to maintain roof and flashings in watertight conditions.

PART II PRODUCTS

2.01 PRODUCT DESCRIPTION

- A. Amp Lok structural standing seam roof system as manufactured by Fabral, 3449 Hempland Road, Lancaster, PA 17601, ph.: 800-477-2741; fax: 800-283-4289.
- B. The Amp Lok panel shall have a coverage of 12", 16", or 18". Seams shall be 2" high.
- C. Roof panels shall use a two-piece roof clip allowing for thermal movement of the panel system.
- D. The panel shall have a factory-applied mastic and be mechanically seamed with a field operated electric seaming machine provided by the manufacturer.
- E. The panel system shall be as a true standing seam shape requiring no trapezoidal foam closures, plugs, or fillers at eaves.
- F. Panels have 1" shadowlines as a standard.

2.02 PRODUCT SUBSTITUTIONS

- A. Requests to use alternate systems shall be submitted in writing to the project designer at least ten (10) days prior to bid date. Request shall demonstrate proposed substitution meets or exceeds specified performance requirements. Certified statements, samples and descriptive data shall be included in this submittal request.
- B. Manufacturers listed in this section are prequalified manufacturers. Substitution of manufacturer's products for those specified shall not be allowed at anytime during construction.

Prestige

SPECIFICATIONS

2.04 MATERIALS AND FINISHES

- A. Panel materials
 - 1. 24 or 22 gauge, Grade 50 (50 ksi yield strength) structural steel with G90 (0.90 oz./ft.²) hot dipped galvanized coating, both conforming to ASTM A 653.
 - 2. 24 or 22 gauge, Grade 50 (50 ksi yield strength) structural steel with AZ50 (0.50 oz./ft.²) aluminum-zinc alloy coating, both conforming to ASTM A792.
- C. Texture: panels shall be smooth.
- D. Finish: paint shall be full strength 70% polyvinylidene fluoride (Kynar[®] 500/ Hylar[®] 5000* fluorocarbon) baked-on coating, factory applied prior to roll forming. The treatment shall be a two-coat system consisting of a single coat of 0.2 mil primer followed by a finish coat of 0.8 mil topcoat with a total dry film thickness of 1.0 mil ± 0.2 mil. The reverse side of the panels shall be treated with a back coat system consisting of a 0.2 mil primer with a 0.3 mil topcoat for a total dry film thickness 0.5 mil.

2.04 ACCESSORIES

- A. Concealed roof clips:
 - 1. 2 pc.: 18 ga. sliding UL90 rated clip designed for thermal movement.
 - 2. 1 pc.: 18 ga. fixed clip (for use with short panel lengths only).
- B. Flashing and Trim
 - 1. All flashing and trim shall be of the same material, gauge, finish, and color as the roof panels and fabricated in accordance with standard SMACNA procedure and details.
 - 2. Provide transition rib covers where roofing changes pitch.
 - 3. Fabricate gutters and downspouts in the same gauge, material, finish, and color as the roof panels.
- C. Fasteners
 - 1. Clips to substrate: Screw shall be #12 or #14 diameter, self tapping type, zinc-plated steel.
 - 2. Flashings to panels: exposed screws shall be zinc plated with a #14 x 7/8" combination steel and neoprene washer, color to match panel.
 - 3. Pop rivets: #43 stainless steel, color finish to match panel.
- D. Sealants
 - 1. Shall not contain oil, asbestos, or asphalt.
 - 2. Factory applied sealant shall be applied in the seam and designed for metal to metal concealed joints.
 - 3. Field applied panel end sealant shall be mastic tape sealant.
 - 4. Exposed sealant shall be one-part polyurethane joint sealant. Coordinate color with roof panels.
- E. Closures
 - 1. Ridge and hip closures shall be protected and supported by a formed metal closure manufactured from the same material, color, and finish as the panels.
 - 2. Metal closures shall be factory-fabricated and field-cut as needed.
- F. Vapor Retarder:
 - 1. Retarder with a permeance of 0.05 or less as determined by ASTM E 98.

2.05 RELATED MATERIALS

- A. Refer to other sections listed in Related Sections paragraph for related materials.

2.06 FABRICATION

- A. Roof panels shall be formed in continuous lengths.
- B. Panels shall to be roll formed on a stationary industrial type rolling mill to gradually shape the sheet metal. Portable rollformers, rented or owned by the installer, are not acceptable.
- C. Fabricate flashings from the same material as the roof system.

2.07 SOURCE QUALITY

- A. Source Quality: obtain metal panels and accessories from a single manufacturer.
- B. Fabrication tolerances: follow tolerances in MCA's Preformed Metal Wall Guidelines.
- C. Tests and inspections
- D. Verification of performance

PART III EXECUTION

3.02 MANUFACTURER'S INSTRUCTIONS

- A. Compliance: Comply with manufacturer's product data, including product technical bulletins, product catalog installation instructions, and product cartons for installation.

3.02 EXAMINATION

- A. Installer shall:
 - 1. Inspect roof purlins and/or roof deck to verify that it complies with shop drawings and is smooth, even, sound, and free of depressions.
 - 2. Report variations and potential problems in writing to the architect.

3.03 INSTALLATION

- A. Conform to the standard set forth in the SMACNA architectural sheet metal manuals and the approved shop drawings detailed for the project.
- B. Install panels plumb, level, and straight with the seams parallel, conforming to the design as indicated.
- C. Install panel system so it is watertight, without waves, warps, buckles or distortions, and allow for thermal movement considerations.
- D. Abrasive devices shall not be used to cut on or near roof panel system.
- E. Apply sealant tape or caulking as necessary at flashing and panel joints to prevent water penetration.
- F. Remove any strippable film immediately upon exposure to direct sunlight.
- G. Hand-crimp seams at each clip or mechanically seam before workers stand on panels.
- H. Seam panels together with electric-powered seaming machine supplied by the panel manufacturer for a weathertight seam.
- I. Vapor retarder: The joints, perimeter, and all openings shall be sealed per the manufacturer's instructions to provide a continuous vapor retarder.
- J. Underlayment (solid substrate):
 - 1. Provide one layer of 30# felt with horizontal overlaps and endlaps staggered between layers.
 - 2. Provide ice and water shield membrane at all valley and eave conditions as well as any area at less than a 3:12 slope.
 - 3. Lay parallel to ridge line with 2½" horizontal laps and 6" vertical laps.

3.04 CLEANING

- A. Dispose of excess materials and debris from jobsite.
- B. Remove filings, grease, stains, marks, or excess sealants from roof panel system to prevent staining.
- C. Protect work from damage from other trades until final acceptance.

* Kynar[®] 500 is a registered trademark of Atofina Chemicals. Hylar[®] 5000 is a registered trademark of Ausimont USA, Inc.